

Devis technique éclairage Salle Kingsey

- 1 Console éclairage Martin M-One (Software Onyx 4.2.1057)
- 32 Pars LED Zoom RGBWA-UV (voir manuel pour description)
Distribué de façon suivante
26 accrocher
6 au sol
- 14 Fixture moving PROY Beam-Spot (voir manuel pour description)
Distribué de façon suivante
10 accrocher
4 au sol
- 9 Fixture moving PROY Spot (voir manuel pour description)
Distribué de façon suivante
7 au FOH
2 au sol sur scène
- 2 Machines à fumer de type bruine

NOTE : Le plan d'éclairage est fixe et ne peut être bouger

THÉÂTRE DU GRAND CHÊNES

DIR. TECHNIQUE: YVON MATHIEU
 CONTACT: 418-333-1112
 VERSION / UPDATE: REVISION: 02

Legend	Symbol	Name	Count
		PROY MOVING SPOT FOH	9
		PROY MOVING BEAM SPOT STAGE	14
		PARS LED ZOOM RGBWU	32

CONCEPTION PAR:
PIERRE ROY

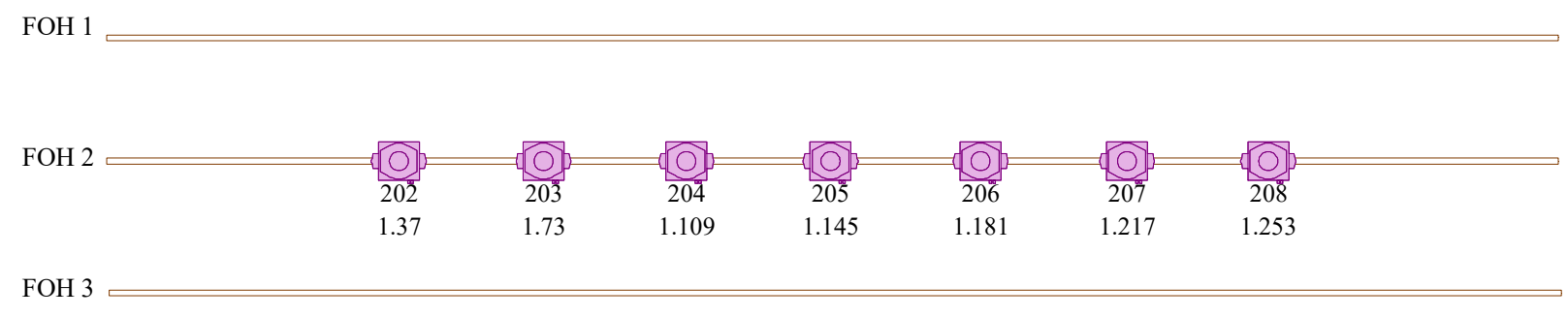
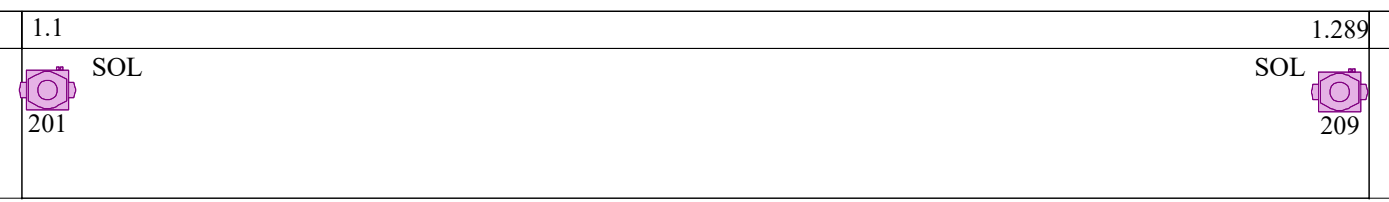
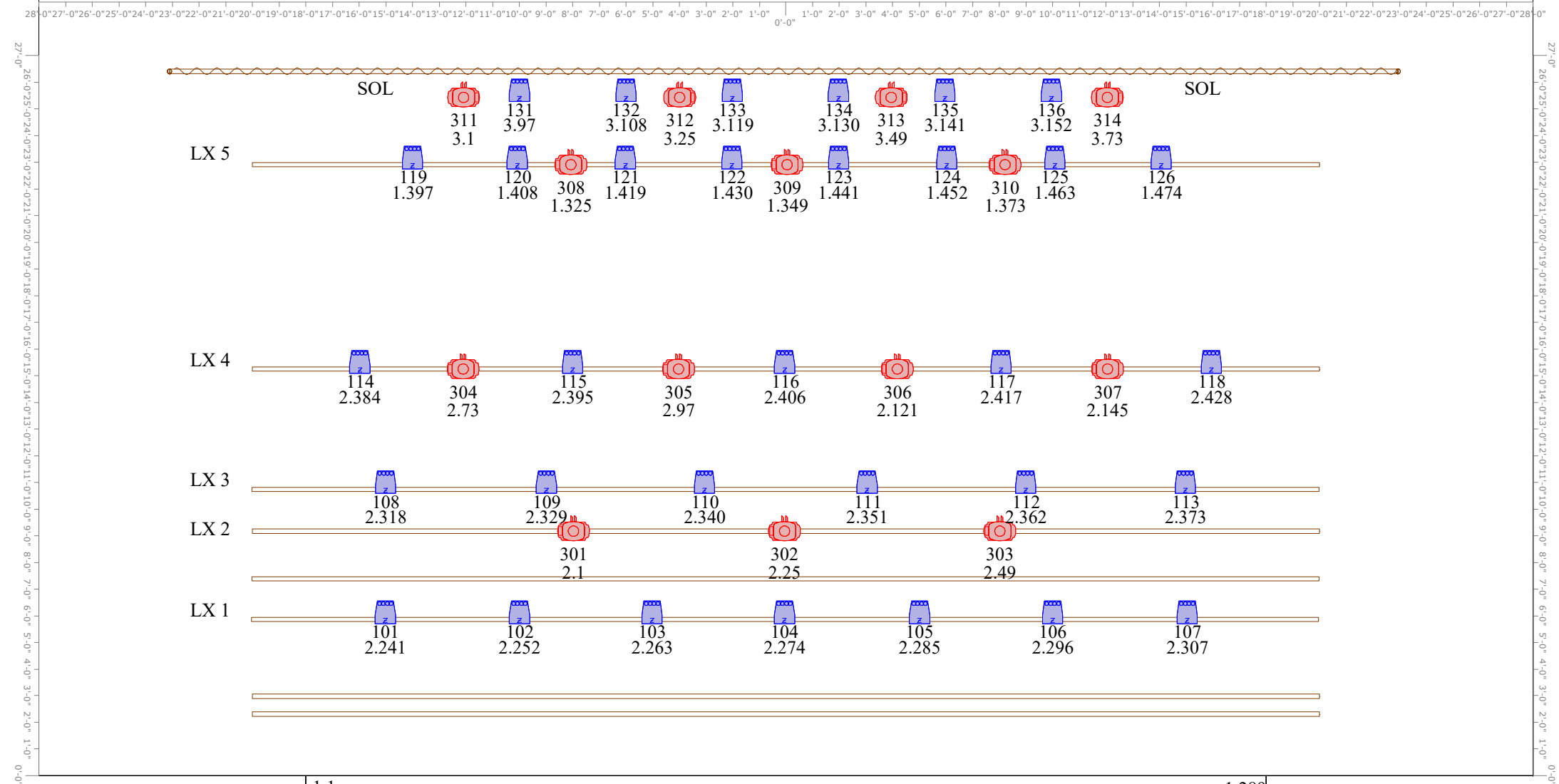

User manual of 32bit_6 color constant current focusing

1. Graphical section:

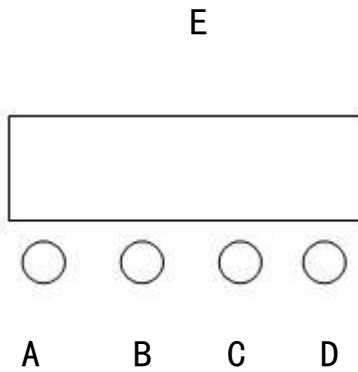

- A. Function Key
- B. Plus Key
- C. Minus Key
- D. Confirm Key
- E. Display window

2. Operation instructions: Press function key A to cycle through 14 different functional effects. The first two digits of the digital tube represent the current function (refer to the function table). The last two digits represent the address code or speed, mode, and parameters of the function. Press B or C to modify its parameter value. Press D key to confirm.

3. Digital display window function comparison table: (All functions are selected and then press D key to confirm and save.)

1	d001	7 channel B.C key plus or minus address code value (001-511)
2	d.001	11 channel B.C key plus or minus address code value (001-511)
3	CC01	Jump function B.C key plus or minus address code value (01-99)
4	CP01	Gradient function B.C key plus or minus address code value (01-99)
5	dE01	Pulse change function B.C key plus or minus address code value (01-99)
6	dENo	Jump + Gradient + Pulse function
7	bEbE	Voice control function Jump + Gradient + Pulse
8	r255	Manual dimming of red light
9	G255	Manual dimming of green light
10	b255	Manual dimming of blue light
11	W255	Manual dimming of white light
12	A255	Manual dimming of amber light
13	Y255	Manual dimming of purple light
14	H255	Zoom

4.DMX7 channel function introduction (.7CH):

Channel	Function	Function control
CH1	RED brightness (Red)	0: off 1-255 dimming
CH2	GREEN brightness (Green)	0: off 1-255 dimming
CH3	BLUE brightness (Blue)	0: off 1-255 dimming
CH4	WHITE brightness (White)	0: off 1-255 dimming
CH5	Amber	0: off 1-255 dimming
CH6	Purple	0: off 1-255 dimming
CH7	Zoom	1-255 zoom

5.DMX11 Channel function introduction (.11CH):

Channel	Function	Function control
CH1	RED brightness (Red)	0: off 1-255 dimming
CH2	GREEN brightness (Green)	0: off 1-255 dimming
CH3	BLUE brightness (Blue)	0: off 1-255 dimming
CH4	WHITE brightness (White)	0: off 1-255 dimming
CH5	Amber	0: off 1-255 dimming
CH6	Purple	0: off 1-255 dimming
CH7	Zoom	1-255 zoom
CH8	Total dimming	0: off 1-255 dimming
CH9	Strobe effect	0-9: off 10-255 From slow to fast
CH10	Self-propelled function	10-50 jump 51-100 Gradient 101-150 Pulse change 151-200 Jump + Gradient + Pulse 201-255 Voice Control
CH11	Function speed	0-255 From slow to fast

6. Features:

The operation is very simple, user-friendly design, dimming without flicker and jitter, etc. It can be adapted to occasions with strict lighting requirements such as photography, photography, TV stations, etc.

380W BEAM MOVE HEAD LIGHT

USER MANUAL

(TFT DISPLAY & TOUCH)



Please read over this manual before operation the light

CONTENTS

Chapter 1	Installation and attention	1
1.1	Maintenance	1
1.2	Statement	1
1.3	Safety Precaution	1
1.4	Product Instruction	1
1.5	Cable connection (DMX)	2
1.6	Rigging (Optional)	2
Chapter 2	Panel operation	4
2.1	Brief	4
2.2	Operation	4
2.2.1	Operate light with touch or KEY	4
2.2.2	Parameter value setting	4
2.2.3	Boolean parameter setting	4
2.2.4	Sub Menu (Parameter)	5
2.3	Operation and parameter instruction	5
2.3.1	ADDR--> Address: Set DMX Address	6
2.3.2	MODE--> WorkMode: Set Light work mode	6
2.3.3	DISP-->DISPLAY: Set display	7
2.3.4	TEST--> TestMode	7
2.3.5	ADVA-->Advanced: Set light run parameter	8
2.3.6	STAT-->Status: View status	9
Chapter 3	Channel description	10
3.1	Channel table	10
3.2	Channel Detail	错误! 未定义书签。
3.2.1	COLOR Detail	错误! 未定义书签。
3.2.2	GOBO Detail	错误! 未定义书签。

Chapter 1 Installation and attention

1.1 Maintenance

- To reduce the risk of electrical shock or fire, do not expose this unit to rain or moisture.
- Intermittently using will extend this item's service life.
- Please clear the fan ,fan net , and optical lens in order to keep good work state.
- Do not use the alcohol or any other organic solvent to wipe the shell.

1.2 Statement

The product has perfect performance and integrity packing. All users should be strictly complying with the warning and operating instructions as stated. Or we aren't in charge of any result by misusing. Any damage resulting by misuse is not within the Company's warranty. Any fault or problem caused by neglecting the manual is also not in the charge of dealers.

Note: All information is subject to change without prior notice.

1.3 Safety Precaution

- In order to guarantee the product's life, please don't put it in the damp places or even the environment over 60degrees.
- Always mount this unit in safe and stable matter.
- Install or dismantle should operate by professional engineer.
- Using lamp, the change rate of power voltage should be within $\pm 10\%$, If the voltage is too high, it will shorten the light's life; If it's not enough, will influence the effect.
- Please restart it 20 minutes later after turning off light , until full-cooling. Frequent switching will reduce the life span of lamps and bulbs; intermittent using will improve the life of bulbs and lamps.
- In order to make sure the product is used well, please read the Manual carefully.

1.4 Product Instruction

- lamp: osram srlrus hrl371w (life:2200 hours Color temperature: 8000K)
- Channel mode:20 DMX512 Channel
- Pan scan: 540°(16bit) Electric correction
- Tilt scan: 270° (16bit) Electric correction
- Amazing dot matix, four tact switch, 180° turning show
- Color wheel: one color wheel, 14 kinds of color chips in one color wheel
- Gobo: 19 gobos
- Effect Wheel: Rotation eight prism, effect move , frost
- 0-100% mechanical dimming, mechanical dimming and free dimming available.
- strobe macro control available.
- Lens optical system achanical fouce .beam angle 0~4°

- Over heat protection
- Power Input: 100-240V, 50/60Hz
- Power Dissipation: 380W
- IP level :IP20
- Magnetic ballast and AC/Dc power supply
- Product Size: 523×337×511mm
- Packing Size: 635X440X725
- Net weight: 19.5KG

1.5 Cable connection (DMX)

Use a cable conforming to specifications EIA RS-485: 2-pole twisted, shielded, 120Ohm characteristic impedance, 22-24AWG, low capacity. Do not use microphone cable or other cable with characteristics differing from those specified. The end connections must be made using XLR type 3 or 5-pin male/female connectors. A terminating plug must be inserted into the last projector with a resistance of 120Ohm (minimum 1/4 W) between terminals 2 and 3.

IMPORTANT: The wires must not make contact with each other or with the metal casing of the connectors. The casing itself must be connected to the shield braid and to pin 1 of the connectors.

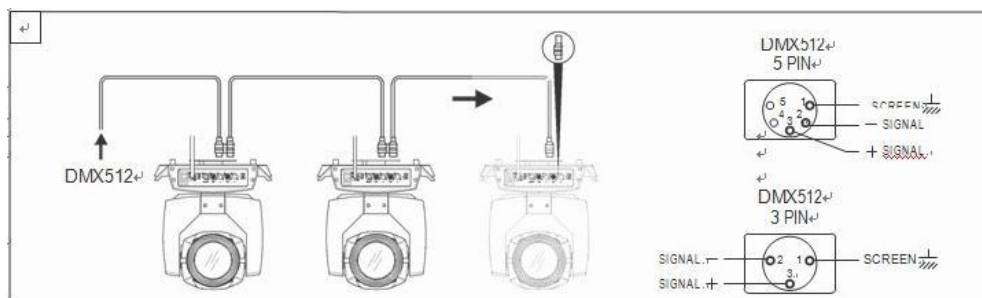

Figure 1 DMX Cable connection

1.6 Rigging (Optional)

This equipment can be positioned and fixed by clamp in every direction of the stage. Locking system makes it easy to fasten to the bracket.

Attention! Two clamps is needed to fix the equipment. Every clamp is locked by fastener of 1/4 kind. Fastener can only be locked clockwise.

Attention! Fasten a safety string to the additional hole of side aluminum piece. The secondary accessory can not hang on the delivery handle. Nip the equipment on bracket.

- Check if rigging clamp (not including the one inside) damaged or not? If stand ten times weight as the equipment. Make sure the architecture can stand ten times weight as all the equipments, clamps, wirings and other additional fixtures.
- Screws for clamping must be fixed firmly. Take one M12 screw (Grade 8.8 or higher) to clamp bracket, and then screw the nuts.
- Level the two hanging points at the bottom of clamp. Insert fastener to the bottom, lock the

two levers by 1/4 rotating clockwise; then install another clamp.

- Install on safety string which stands at least ten times weight as equipment. Terminal of the accessory is designed for clamps.
- Make sure pan/tilt lock unlocked or not. Keep the distance more than 1M from equipment to flammable material or lighting source.

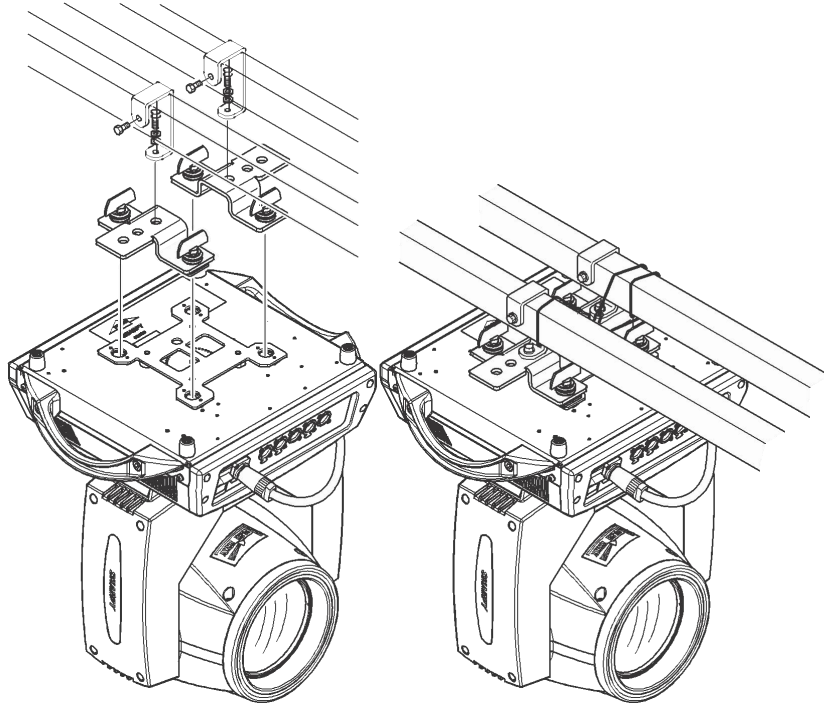

Figure 2 Installation

Chapter 2 Panel operation

2.1 Brief

The light panel diagram show as Figure 3, Left area is TFT Displayer, support touch, and right area is KEY, both of touch and KEY can operate light and setting.

Display & operation just like 'Android operation system', touch the item will set or modify setting.

Note: Prevent damage the touch or TFT displayer, Can not use sharp objects chick displayer.



Figure 3 Panel diagram

2.2 Operation

2.2.1 Operate light with touch or KEY

- The left area is TFT Displayer and touch, click item or value with finger will to complete operation of set light setting(parameters) or view light state.
- The area on the right hand side is 4 KEY, As auxiliary input interface, if disable touch function,, the KEYr can be choose to set the parameter.

2.2.2 Parameter value setting

When the selected item is value need to been modified, the dialog shown in Figure 4 will popup.

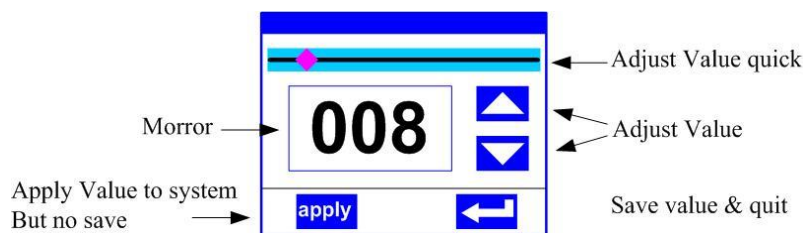

Figure 4 Dialog of value setting

- **Modify value:** Can quickly modify value via pull the slider to the desired position, or click the button of 'up' or 'down' whit finger on the right side to set the exact desired value, another way is roll encoder on the right hand side of panel.
- **Apply value:** When Value had been modified, Then press the bottom of 'apply' in the left corner to apply to the light, but hav't saved;
- **Save Value:** Any time, click on the lower right corner of the "OK" button, the setting will been saved into internal memory.

2.2.3 Boolean parameter setting

- when the selected parameters is a Boolean value (such as ON or OFF), can directly modify

setting by click corresponding item, the setting will be saved right now.

- When the parameter is a key item, click corresponding item, a dialog shown in Figure 5 will be popup ask for the confirm. Click 'sure' to confirm.

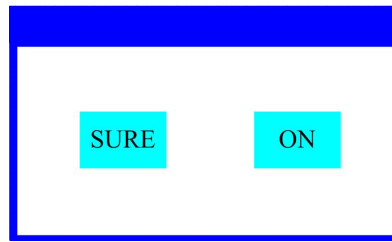

Figure 5 Dialog of confirm

2.2.4 Sub Menu (Parameter)

Click item of main menu, enter corresponding sub menu, shown in Figure 6, total 6 sub menu, includes class of parameter and status:

- ADDRESS: Set light DMX address.
- WORKMOD: Set light work mode, master or slave mode when in auto run mode.
- DISPLAY: Set display parameter, eg. select language.
- TEST: Used for test light, modify DMX channel data to test function, the corresponding function of reference channel function table.
- ADVANCE: Set light running parameter.
- STATUS: view light current status.



图 6-1地址设置



图 6-2运行设置



图 6-3显示设置



图 6-4场景设置



图 6-5高级设置



图 6-6状态信息

Figure 6 Parameter menu

2.3 Operation and parameter instruction

Via following operation, enter sub menu(parameter menu) shown in Figure 6

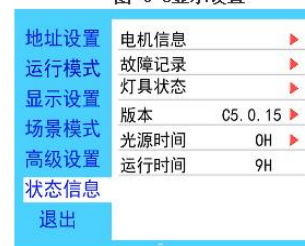
- In main menu, click 1/6 function button into corresponding parameter menu.
- In sub menu(page), click main item on the left side of displayer, can shift to corresponding sub menu(page) quickly.

2.3.1 ADDR--> Address: Set DMX Address

Click and select the "ADDR", can enter the page of DMX address setting, range from 1 to 512, the address code shouldn't is not greater than (512- channels quantity), otherwise the light will not be controlled. Following is the operation:

Enter the page of DMX address, as shown in Figure 7, click the blank area in right side of display will pop-up diglog as in Fig. 4, modify value, then click 'ENTER' to confirm and save DMX address code.

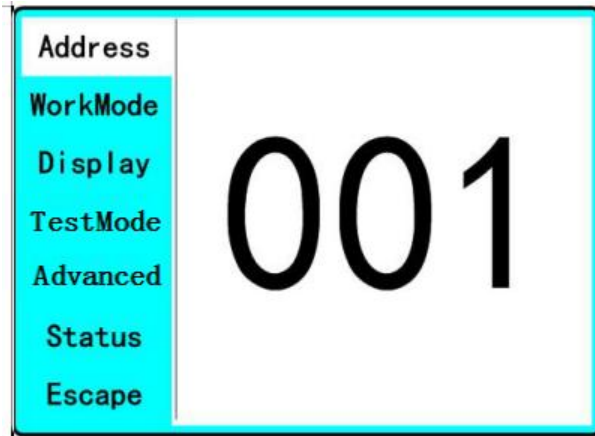

Figure 7 page of DMX Address

2.3.2 MODE--> WorkMode: Set Light work mode

Enter the page of 'WorkMode' as shown in Figure 8 and modify setting. Can set light work mode, control lamp and DMX channel mode.

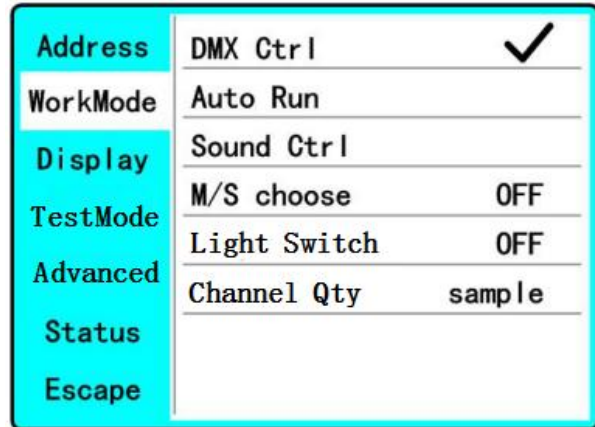

Figure 8 page of work mode

- ◆ **DMX Ctrl:** Choose to set DMX Mode,
- ◆ **Auto Run:** Choose to set Auto Mode,
- ◆ **Sound Ctrl:** Choose to set Sound Mode,
- ◆ **M/S Choose:** Available just in 'AUTO RUN' or 'SOUND Ctrl' mode.
ON--> Master. (Data will be send to other slave lamp immediately.)
OFF--> Slaver.(NOT send data to other lamp via DMX Cable).(Default)
- ◆ **Light Switch:**
ON--> Turn on the light,
OFF--> Turn off the light.
- ◆ **Channel Qty:** Light support 2 DMX Channel mode: sample or extend.
Simple --> 16CH.(Default)
Expand--> 20CH(or null).

2.3.3 DISP-->DISPLAY: Set display

Light support 2 language, rotation display , Enter page as shown in Figure9 to set parameter following:

Address	语言	English
WorkMode	Screen saver	Mode3
Display	Screen rotation	OFF
TestMode	Touch Enable	ON
Advanced	Touch Rectify	
Status		
Escape		

Figure9 page of display

- ◆ **Language:** English / 中文.
- ◆ **Screen Saver:** when panel is idle(these is no operation in 10 second), displayer will enter saver status.
 - OFF--> No screen saver.
 - Mode1--> Power-saving mode, turn off the display.
 - Mode2--> Displays the current address.
 - Mode3--> Displays the icon and the current working mode.(Default)
- ◆ **Screen Rotion: To turning display.**
 - ON--> Normal display.(Default)
 - OFF--> 180° turning display.
- ◆ **Touch enable:** Disable or enable touch function,.
 - ON--> Enable touch function.(Default)
 - OFF--> Dosable touch function.
- ◆ **Touch adjust:** Adjust touch function. Normally, not enter this item.

2.3.4 TEST--> TestMode

Enter the page as shown in Figure 10, Light will into test mode, in this mode, the light does not receive the data for DMX controller.:

Address	PAN	000
WorkMode	TILT	000
Display	FOCUS	000
TestMode	COLOR	000
Advanced	GOBO	000
Status	PRISM	000
Escape	FROST	000
	STROBE	000

Figure 10 page of Test

- ◆ **PAN:** range for 0 to 255;

- ◆ **TILT:** range for 0 to 255;
- ◆ **FOCUS:** range for 0 to 255;
- ◆ **COLOR:** range for 0 to 255;
- ◆ **GOBO:** range for 0 to 255;
- ◆ **PRISM:** range for 0 to 255;
- ◆ **FROST:** range for 0 to 255;;
- ◆ **STROBE:** range for 0 to 255;

2.3.5 ADVA-->Advanced: Set light run parameter

Enter the page as shown in Figure 10, set the parameter of light:

Address	PAN Inset	OFF
WorkMode	TILT Inset	OFF
Display	P/T Rectify	ON
TestMode	PAN Offset	010
	TILT Offset	010
Advanced	Lamp when	Power ON
Status	Data hold	OFF
Escape	Factory Setting	

Figure 11 page of run parameter

- ◆ **Pan Invert:** Reverse PAN move
OFF--> Pan Normal move.(Default)
ON--> Reverse PAN move.
- ◆ **Tilt Invert:** Reverse TILT move
OFF--> Tilt Normal move.(Default)
ON--> Reverse Tilt move.
- ◆ **P/T Rectify:** Disable or enable position rectify function.
OFF--> Disable P/T rectify
ON--> Enable P/T rectify-(Default)
- ◆ **Pan Offset:** Set PAN original position. **Default: 10**
- ◆ **Tilt Offset:** Set TILT original position. **Default: 10**
- ◆ **Lamp when:**
PowerON--> Turn on the lamp when power on.(Default)
RstDone--> Turn on the lamp after reset.
Manual--> Manually turn on the lamp.
- ◆ **Data hold:**
OFF--> When no DMX signal,return to middle position.(Default)
ON--> When no DMX signal,stop in the final position.
- ◆ **Factory Setting:** Restore all parameter to factory setting.

2.3.6 STAT-->Status: View status

Enter the page as shown in Figure 12:

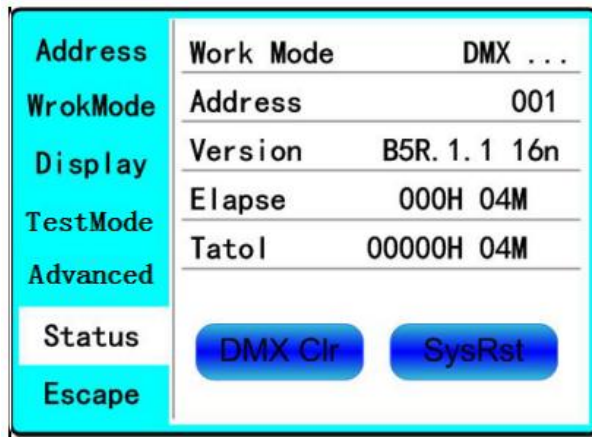
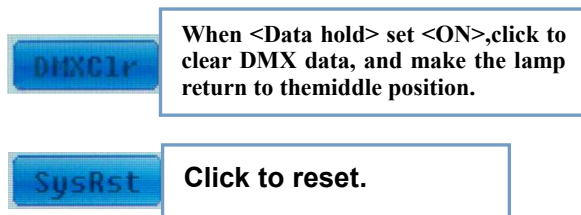

Figure 12 page of status

- ◆ **Work Mode:** Show the current working mode.
- ◆ **Address:** Show the current address.
- ◆ **Version:** Show the version of the lamp.
- ◆ **Elapse:** Working hours after turn on.
- ◆ **Tatol:** Cumulative hours of operation



Chapter 3 Channel description

3.1 Channel table

Table 1 Channel brief

CHANNEL	NAME	VALUE	DERIF
CH1	The X axis	0-255	0-540 degrees
CH2	The X axis fine-tuning	0-255	0-2 degrees
CH3	Y	0-255	0-270 degrees
CH4	Y fine-tuning	0-255	0-1 degrees
CH5	XY speed	0-255	From fast to slow
CH6	reset	100-105	Turn off light cannon for more than 6 seconds
		200-205	More than 6 seconds on the light cannon
		240-255	All reset after 6 seconds
CH7	C	0-255	0-100%
CH8	M	0-255	0-100%
CH9	Y	0-255	0-100%
CH10	Color 1	0-18	The white light
		19-36	White light + color 1
		37-54	Color 1
		55-72	Color 1 plus color 2
		73-90	Color 2
		91-108	Color 2 plus color 3
		109-127	Color 3
		128-191	From fast to slow forward water
192-255	From slow to fast reverse flow		
CH11	Color 2	0-18	The white light
		19-36	White light + color 1
		37-54	Color 1
		55-72	Color 1 plus color 2
		73-90	Color 2
		91-108	Color 2 plus color 3
		109-127	Color 3
		128-191	From fast to slow forward water
192-255	From slow to fast reverse flow		
CH12	Color 3	0-18	The white light
		19-36	White light + color 1
		37-54	Color 1
		55-72	Color 1 plus color 2
		73-90	Color 2
		91-108	Color 2 plus color 3
		109-127	Color 3
		128-191	From fast to slow forward water

		192-255	From slow to fast reverse flow
CH13	Effect of pattern	0-14	The white light
		15-29	Design 1
		30-44	Design 2
		45-59	Design 3
		60-74	Design 4
		75-89	Shake pattern 1 from slow to fast
		90-104	Shake pattern 2 from slow to fast
		104-114	Shake pattern 3 from slow to fast
		115-127	Shake pattern 4 from slow to fast
		128-255	From slow to fast circulating water
CH14	pattern	0-4	The white light
		5-9	Design 1
		10-14	Design 2
		15-19	Design 3
		20-24	Design 4
		25-29	Design 5
		30-34	Design 6
		35-39	Design 7
		40-44	Design 8
		45-49	Design 9
		50-54	Design 10
		55-59	Design 11
		60-64	Design 12
		65-69	Shake pattern 1 from slow to fast
		70-74	Shake pattern 2 from slow to fast
		75-79	Shake pattern 3 from slow to fast
		80-84	Shake pattern 4 from slow to fast
		85-89	Shake pattern 5 from slow to fast
		90-94	Shake pattern 6 from slow to fast
		95-99	Shake pattern 7 from slow to fast
100-104	Shake pattern 8 from slow to fast		
105-109	Shake pattern 9 from slow to fast		
110-114	Shake pattern 10 from slow to fast		
115-119	Shake pattern 11 from slow to fast		
120-124	Shake pattern 12 from slow to fast		
125-190	From fast to slow forward water		
191-192	stop		
193-255	From slow to fast reverse flow		
CH15	Rotating pattern	0-9	The white light
		10-19	Design 1
		20-29	Design 2
		30-39	Design 3
		40-49	Design 4
		50-59	Design 5
		60-69	Design 6

		70-79	Design 7
		80-89	Shake pattern 1 from slow to fast
		90-99	Shake pattern 2 from slow to fast
		100-109	Shake pattern 3 from slow to fast
		110-119	Shake pattern 4 from slow to fast
		120-129	Shake pattern 5 from slow to fast
		130-139	Shake pattern 6 from slow to fast
		140-149	Shake pattern 7 from slow to fast
		150-199	From fast to slow forward water
		200-255	From slow to fast reverse flow
CH16	Design the rotation	0-127	0-360 degrees
		128-190	From fast to slow forward water
		191-192	stop
		193-255	From slow to fast reverse flow
CH17	Prism 1	0-63	There is no
		64-127	Insert prism 1
		128-191	Insert prism 2
		192-255	Prism 1+ prism 2
CH18	Rotation of prism 1	0-127	0-360 degrees
		128-187	From fast to slow forward water
		188-195	stop
		196-255	From slow to fast reverse flow
CH19	atomization	0-127	There is no
		128-255	atomization
CH20	amplification	0-255	From small to large
CH21	focusing	0-255	From far to near
CH22	Focusing fine-tuning	0-255	
CH23	stroboscopic	0-3	GuanGuang
		4-103	Slow to fast pulse stroboscopic
		104-107	medallion
		108-207	Slow to fast gradually variable frequency flash
		208-212	medallion
		213-251	Slow to fast random stroboscopic
		252-255	medallion
C24	The dimmer	0-255	0-100% dimmer



700W LED Spot Cutting Moving Head Light

User Manuel

Thanks for choosing our goods please read this manual carefully before your operating

Content

1. Open-package Inspection.....	2
2. Product Introduction.....	2
3. Attentions.....	2
4. Technical Parameter.....	2
5. Channel Mode.....	4
6. Installation.....	6
7. Installation and change of the Lamp.....	7
8. The connecting of the signal cable.....	7
9. Button Instruction.....	8
10. Maintain.....	9
11. Fixture Cleaning.....	9
12. Statement.....	9

First of all thank you for buy our products. Please read this user manual completely and carefully, and keep it well for reference when needed. This use manual includes important information about the installation and using of the moving head. Please hew to the relevant specification strictly when install and use this product.

1. Open-package Inspection

After receiving the product, please be careful to take and put. Check if the product has been damaged during the transportation, and check the following parts:

The body-----1pc User manual ----- -1pc

Power cable -----1pc signal cable-----1pc

2. Product Introduction

This Moving head light is made of new high strength heat-resistant engineering plastic and cast aluminum shell, with beautiful design and smooth outlook, Is the representative of the modern lights. This product strictly according to CE standard design and production, fully comply with international standard DMX 512 protocol. Can be single control, also can use integrated with each other. It is suitable for large-scale theatrical performances, theaters, studio and disco and other places.

3. Attentions

To ensure the service life of the product, please keep it away from water and do not work in the environment which the temperature is above sixty degrees.

Don't put the product on the place easy to lose or easy vibration.

In order to avoid electric shock, this product must maintenance by professional person.

When using, the power supply voltage change should not be more than 10%, the voltage is too high, will shorten the life of the light bulb, the voltage is too low, then affects the light color.

When power off, the product needs 20 minutes to sufficient cooling before use again.

To ensure the normal use, please read this user manual carefully.

4. Technical Parameter

4.1 Setting

Voltage: AC 110-240V, 50/60Hz

Input power: 600W

Fuse: 5A

Source specification: High power 600W white LED

Average life: 2000H (bulb and reflector complete package, light efficiency and long service life)

Ballast: Electronic ballast

Color temperature: 6500K

4. 2 Product specification

1. Signal Control: DMX512 international standard signal
2. DMX Channel: 36 Channels
3. CRI: ≥ 74 / ≥ 90
4. Pan movement: $540^\circ/630^\circ$ optional (16 bit)
5. Tilt movement: 270° (16 bit)
6. Advanced moving system: fast, stable and quiet, auto X-Y repositioning
7. CTO color temperature linear change
8. 1 Color wheel:6 dichroic filters +open, half color; Indexable ,rainbow effect
9. 1 Rotating gobo wheel: 6 interchangeable, rotating, indexable, gobos+open, gobo shaking
10. 1 Static gobo wheel: 8 indexable, gobos+open, gobo shaking
11. Animation wheel: can make special dynamic effect like flame or water effect,etc.
12. 2 Operational modes: DMX-512, Master/Slave
13. Prism: 3 facets rotating prism with 6-row prism; can rotate with both directions, prisms overlay and location effect
14. Focus: motorized focus
15. Iris: motorized linear change from 5%-100%
16. Shutter: variable from 1-25flashes or random strobe
17. Dimming: 0-100% linear dimming
18. 3 Frost level: heavy, medium and light
19. Zoom: 4.5° - 50° linear zoom
20. Cutting wheel: With 4 cutting discs to organize a cutting spot system, cutting system can rotate 90degree.Precise control of cutting disc
21. Can create triangle, diamond and rectangle light spots in any direction
22. Minimum angle with 5M distance; Spot diameter: 43cm
23. Maximum angle with 5M distance; Spot diameter: 466cm
24. DISPLAY:Advanced and convenient full-color LCD touch button screen
25. With RDM
26. Dimension: 510L*345W*800H(mm)
27. Net Weight: 40kg
28. Gross Weight: 43kg

5. Channel Mode

DMX512Channel

Channels	Name	Value	Description
CH1	Pan	0-255	0-540 degree
CH2	Pan fine	0-255	0-2 degree
CH3	Tilt	0-255	0-270 degree
CH4	Tilt fine	0-255	0-1 degree
CH5	P/T Speed	0-255	Fast to slow
CH6	Strobe	0-3	Off
		4-127	Pulse strobe Slow → fast
		128-191	Gradual strobe Slow → fast
		192-251	Random strobe Slow → fast
		252-255	On
CH7	Dimming	0-255	0-100% dimming
CH8	C	0-255	
CH9	M	0-255	
CH10	Y	0-255	
CH11	CTO	0-255	
CH12	Color	0-127	Linear Color
		128-137	Color 1
		138-146	Color 2
		147-155	Color 3
		156-164	Color 4
		165-173	Color 5
		174-182	Color 6
		183-191	Color 7
		192-222	Forward rotation Fast → slow
		223-224	Stop
225-255	Reverse rotation Slow → fast		
CH13	Value	0	Blank
		1-255	0-100% linear insertion
CH14	Gobo	0-9	White
		10-19	Gobo 1
		20-29	Gobo 2

		30-39	Gobo 3
		40-49	Gobo 4
		50-59	Gobo 5
		60-69	Gobo 6
		70-79	Gobo 1 shaking Slow → fast
		80-89	Gobo 2 shaking Slow → fast
		90-99	Gobo 3 shaking Slow → fast
		100-109	Gobo 4 shaking Slow → fast
		110-119	Gobo 5 shaking Slow → fast
		120-129	Gobo 6 shaking Slow → fast
		130-190	Forward rotation Fast → slow
		191-192	Stop
		193-255	Reverse rotation Slow → fast
CH15	Rotating Gobo	0-9	White
		10-19	Gobo 1
		20-29	Gobo 2
		30-39	Gobo 3
		40-49	Gobo 4
		50-59	Gobo 5
		60-69	Gobo 6
		70-79	Gobo 1 shaking Slow → fast
		80-89	Gobo 2 shaking Slow → fast
		90-99	Gobo 3 shaking Slow → fast
		100-109	Gobo 4 shaking Slow → fast
		110-119	Gobo 5 shaking Slow → fast
		120-129	Gobo 6 shaking Slow → fast
		130-190	Forward rotation Fast → slow
		191-192	Stop
193-255	Reverse rotation Slow → fast		
CH16	Pattern rotation	0-127	0-400 degree
		128-190	Forward rotation Fast → slow
		191-192	Stop
		193-255	Reverse rotation Slow → fast
CH17	Effect insertion	0-10	Move
		11-255	Linear insertion
CH18	Effect Wheel	0-2	Stop

		3-128	Forward rotation Fast → slow
		129-255	Reverse rotation Slow → fast
CH19	Focus	0-255	Far → Close
CH20	Focus fine		
CH21	Zoom	0-255	Small → Large
CH22	Prism	0-63	Off
		64-127	Prism-1
		128-191	Prism-2
		192-255	Prism-1+Prism-2
CH23	Prism1-Rot	0-127	0-400 degree
		128-187	Forward rotation Fast → slow
		188-195	Off
		196-255	Reverse rotation Slow → fast
CH24	Prism2-Rot	0-127	0-400 degree
		128-187	Forward rotation Fast → slow
		188-195	Off
		196-255	Reverse rotation Slow → fast
CH25	Frost	0-127	Blank
		128-255	Frost
CH26	Slice 1	0-255	Linear insertion
CH27	Slice 2	0-255	Linear insertion
CH28	Slice 3	0-255	Linear insertion
CH29	Slice 4	0-255	Linear insertion
CH30	Slice 5	0-255	Linear insertion
CH31	Slice 6	0-255	Linear insertion
CH32	Slice 7	0-255	Linear insertion
CH33	Slice 8	0-255	Linear insertion
CH34	Cutting Plate	0-255	Cutting plate angle (0-90 degree)
CH35	Iris	0-255	Large → Small
CH36	Function	210-215	Reset XY after 3 seconds
		220-235	Reset effective motor after 4 seconds
		240-255	Reset all after 5 seconds

6. Installation

Before install, please make sure the power supply is the same as the product identified.

The cable connecting to the main power supply must meet the requirements, should not overload.

The installation must be done by professional person, fixed the light safely and reliable, and transferred to appropriate irradiation angle.

Please ensure that the draft fan and exhaust channel is not blocked

At the bottom of the moving head light with insurance line connection hole, based on safety reasons, please use the insurance rope which can withstand ten times the weight of the Moving head through the insurance line connection hole for auxiliary lifting.

When install this equipment, please ensure that at least 1.5 meters range no extreme inflammable and explosive items(ornaments, etc.) ensure the moving head light and the wall interval twenty centimeters of above.

This product can be fixed hanging installation and put on the floor to use.

Based on the safety, please make sure the earth wire grounded.

The Pan and Tilt of this product was locked when packing, please ensure it was unlocked before the power on.

7. Installation and change of the Lamp

In order to prolong the life of the moving head light as far as possible, please choose the same type of lamp for it.

First of all to unscrew the four screws on the back cover of the moving head light, then open the back cover, pinch the ceramic holder of the bulb and anti-clockwise rotation 90°, take out the lamp.

Open the bulb packing carefully, take out the new lamp, pinch lamp ceramic holder, insert the lamp holder and 90° clockwise rotation.

8. The connecting of the signal cable

Connected the XLR control cable from the DMX controller's outlet to the first moving head light's input port , and connected from the first light's DMX outlet to the second light's DMX input port, repeating the process, until all the lights are of connection. Then connected the accompanied circuit plug to the last light's signal output port, the connection finished, as shown in figure:

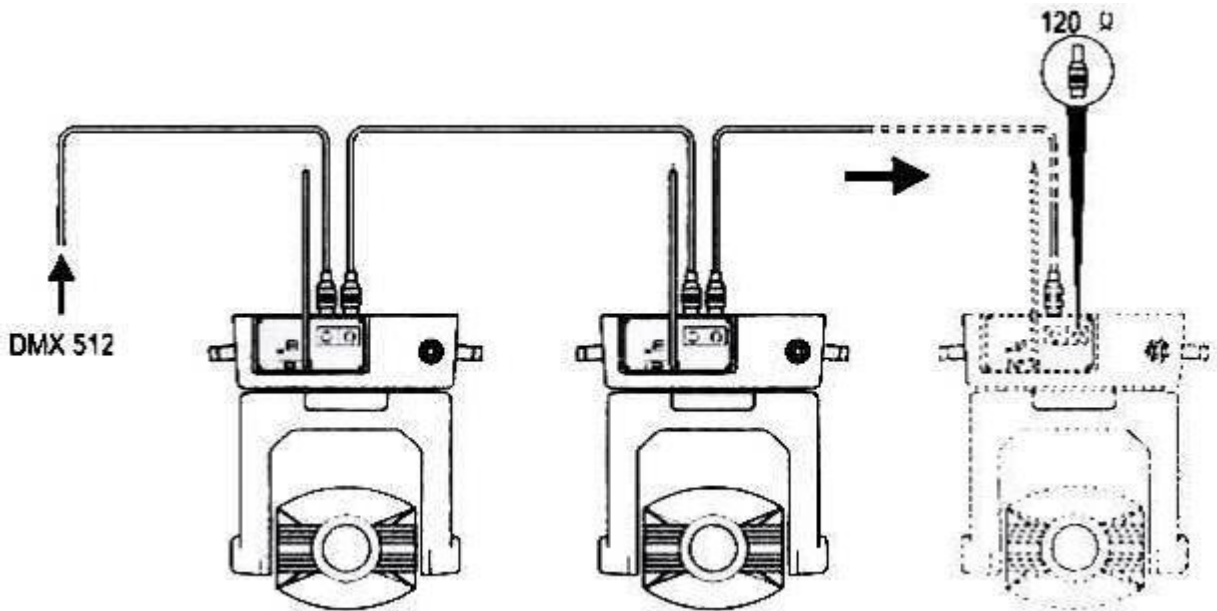

Note: please remember to connect a circuit plug to the last moving head light's signal output port. Between the second and third pole of the CANON plug of this circuit plug have a 120Ω resistance, connect this circuit plug can avoid signal reflection phenomenon during the DMX512 signal transmission process.

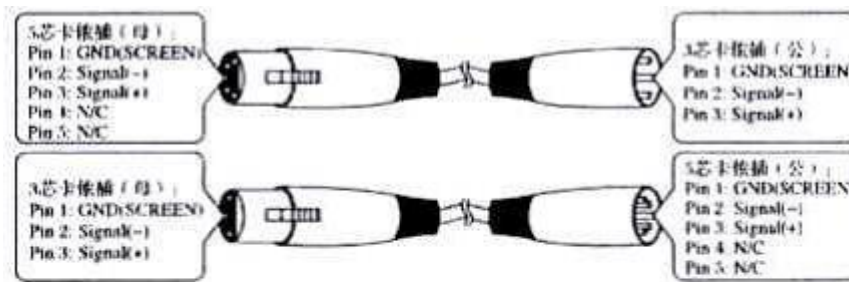

三芯卡依插 (Canon) DMX512接口线路

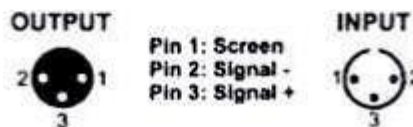

This moving head use 3 pin XLR plug. If your controller used 5 pin XLR plug, you must use a 5 pin to 3 pin patch cord. See above.

9. Button Instruction

- MENU - To select the programming functions
- DOWN - To go backward in the selected functions
- UP - To go forward in the selected functions
- ENTER - To confirm the selected functions

10. Maintain

Keep dry, and avoid working in damp conditions

Intermittent use can effectively prolong the service life of the lamps.

In order to obtain the good ventilation effect and lighting effects, you'd better to clean the fan, fan nets and lens often.

Do not use organic solvent such as alcohol. To wipe the lamps shell, it may cause some damage.

11. Fixture Cleaning

The cleaning of internal and external optical lenses and/or mirrors must be carried out periodically to optimize light output. Cleaning frequency depends on the environment in which the fixture operates: damp, smoky or particularly dirty surrounding can cause greater accumulation of dirt on the unit's optics.

- Cleaned with soft cloth using normal glass cleaning fluid.
- Always dry the parts carefully.
- Clean the external optics at least every 20 days. Clean the internal optics at least every 30/60 days.

12. Statement

This product was in good performance condition and completely packed before delivery. All users should strictly abide by the above statement warnings and instructions. Any damage caused by misuse is not within the company warranty, and the company will not be responsible for the cause of damage because of the operator's ignorance of this user manual.